

MAXHUB ST41B Product Specification

Appearance

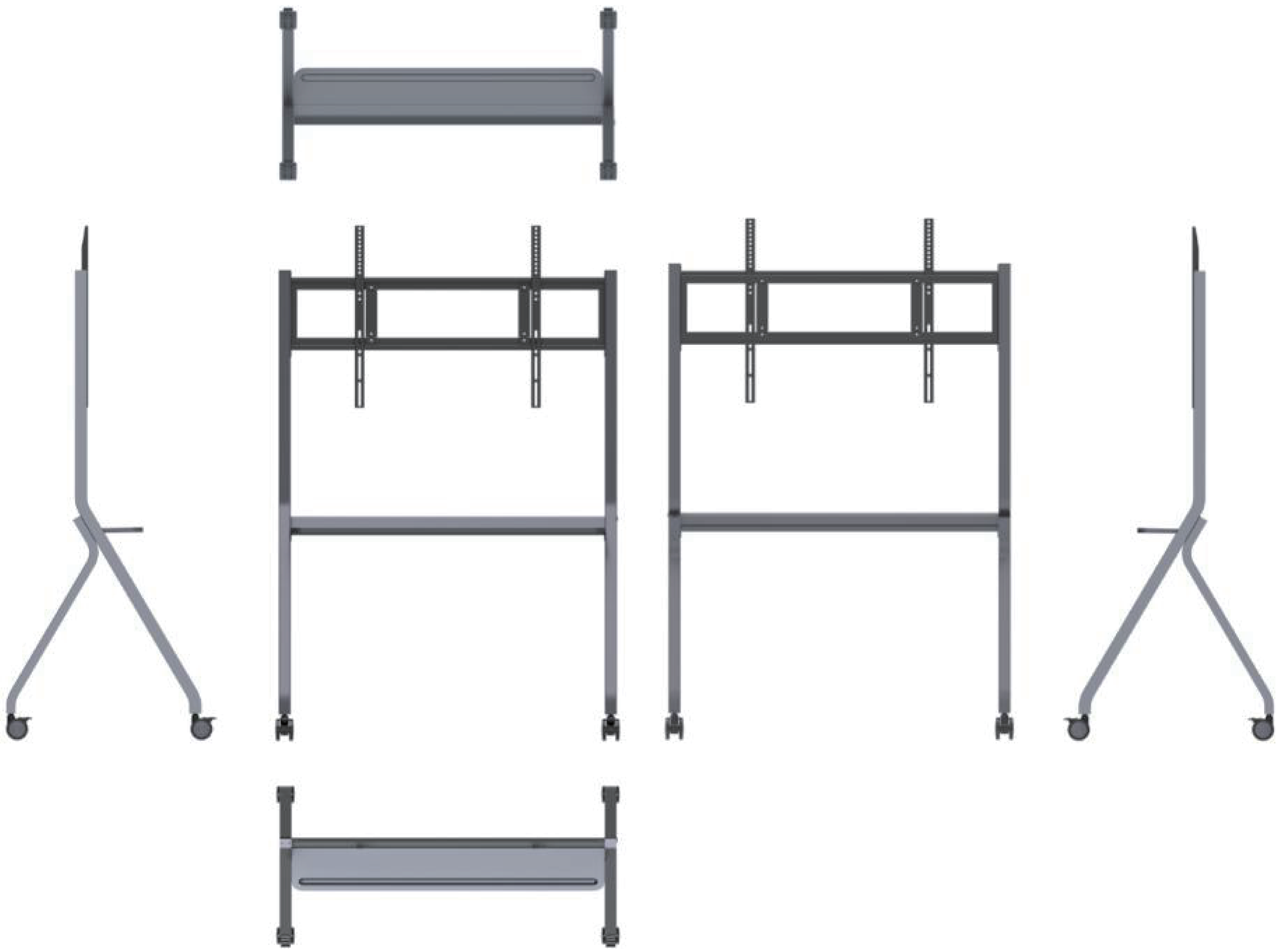

ST41B

Dimensions

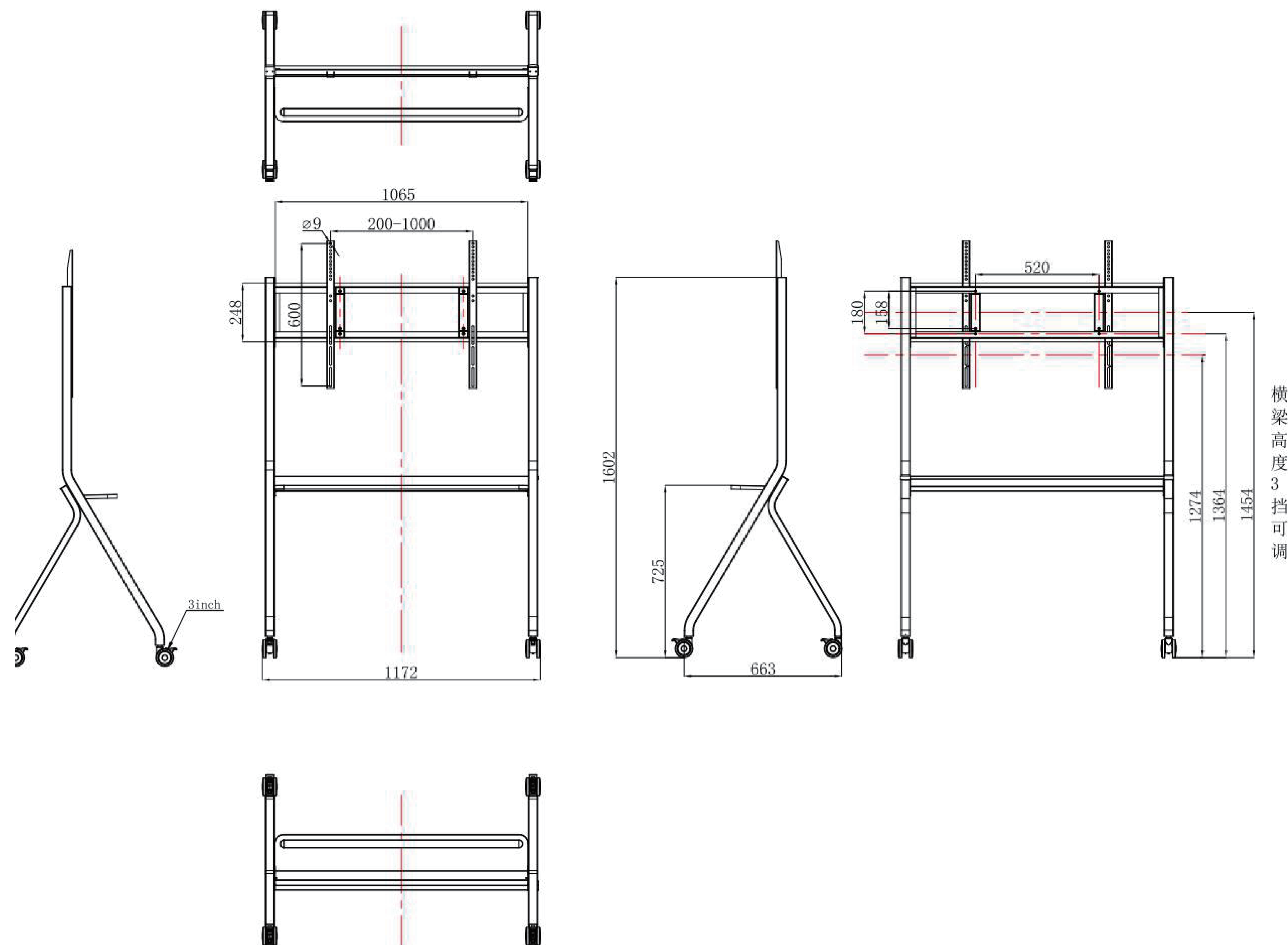

Physical Specifications

Dimension (L×W×H)	1172 × 663 × 1602mm
Dimension with Package (L×W×H)	1625 × 765 × 160mm
Net Weight	17kg
Gross Weight	21kg
Max Load	100kg
Max Load Size	Recommend No more than 86 inch 98 and 105 inch products cannot be hung in the topmost screw hole position
Castor Size	3inch
Castor Type (mute /Non mute)	mute
Matching Wall Mount	WIB6540A/WIB9060F/WIB9060G
Color	Gray (bracket), Black (Hanging plate)

Accessories

Screw Accessory Package	× 1
Wall Mounts	× 2 Optional
Installation Manual	× 1

Environmental Conditions

Operation Temperature	0°C - 40°C
Operation Humidity	10% - 90%RH
Storage Temperature	-20°C -60°C
Storage Humidity	10% - 90%RH

Statement

The product pictures of this specification only indicate that there may be slight difference in product effects (included but not limited to appearance, color and size). Please refer to the product. Due to the influence of product configuration and manufacturing process, the actual size/weight of the fuselage may differ.

In order to provide accurate specification parameters and product characteristics as much as possible, it is possible to adjust and revise the text description and picture effect of this specification in real time, so as to match the actual product performance, specifications and other information.

No special notice will be given if necessary.